

OPERATOR'S MANUAL

66615X-X-C

INCLUDING: OPERATION, INSTALLATION AND MAINTENANCE

RELEASED: 5-31-88

1-1/2" DIAPHRAGM PUMP

REVISED: 2-26-21
(REV: AK)

1:1 RATIO (METALLIC)



**READ THIS MANUAL CAREFULLY BEFORE INSTALLING,
OPERATING OR SERVICING THIS EQUIPMENT.**

It is the responsibility of the employer to place this information in the hands of the operator. Keep for future reference.

SERVICE KITS

Refer to the Model Description Chart to match the pump material options.

637118-C for air section repair (see page 8).

637124-XX for fluid section repair (see page 5).

637155 Abrasion Resistant Conversion Kit is available for use in heavy and abrasive material applications (see page 5).

PUMP DATA

Models see "Model Description Chart" for "-XXX"

Pump Type Metallic Air Operated Double Diaphragm

Material see "Model Description Chart"

Weight Aluminum 51.54 lbs (23.4 kgs)

Cast Iron 79.54 lbs (36.1 kgs)

Stainless Steel... 77.5 lbs (35.15 kgs)

[add 23 lbs (10.4 kgs) for cast iron air motor section]

Maximum Air Inlet Pressure 120 psig (8.3 bar)

Maximum Material Inlet Pressure... 10 psig (0.69 bar)

Maximum Outlet Pressure 120 psig (8.3 bar)

Maximum Flow Rate (flooded inlet) 90 gpm (340.7 lpm)

Displacement / Cycle @ 100 psig

Standard Diaphragm 0.64 gal. (2.42 lit.)

Composite PTFE Diaphragm 0.40 gal. (1.52 lit.)

Maximum Particle Size 1/4" dia. (6.4 mm)

Maximum Temperature Limits (diaphragm / ball / seat material)

Acetal -20° to 180° F (-29° to 82° C)

E.P.R -60° to 280° F (-51° to 138° C)

Hytrel® -20° to 180° F (-29° to 82° C)

Kynar® PVDF 10° to 200° F (-12° to 93° C)

Neoprene 0° to 200° F (-18° to 93° C)

Nitrile 10° to 180° F (-12° to 82° C)

Polypropylene 32° to 175° F (0° to 79° C)

Polyurethane -10° to 150° F (-23° to 66° C)

PTFE 40° to 225° F (4° to 107° C)

Composite PTFE 14° to 194° F (-10° to 90° C)

Santoprene® -40° to 225° F (-40° to 107° C)

Viton® -40° to 350° F (-40° to 177° C)

Dimensional Data see page 10 and 11

Noise Level @ 70 psig - 60 cpm® 80.5 dB(A)®

① Tested with 350-568 muffler installed.

② The pump sound pressure levels published here have been updated to an Equivalent Continuous Sound Level (LA_{eq}) to meet the intent of ANSI S1.13-1971, CAGI-PNEUROP S5.1 using four microphone locations.

NOTICE: All possible options are shown in the chart. However, certain combinations may not be recommended, consult a representative or the factory if you have questions concerning availability.

66615X-XXX-C 1-1/2" DIAPHRAGM PUMP

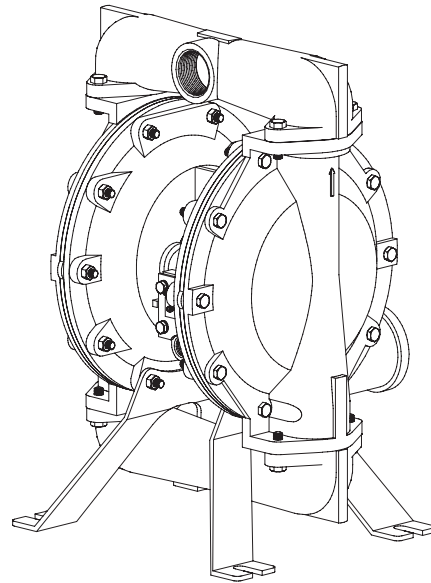

ALUMINUM / CAST IRON PUMP

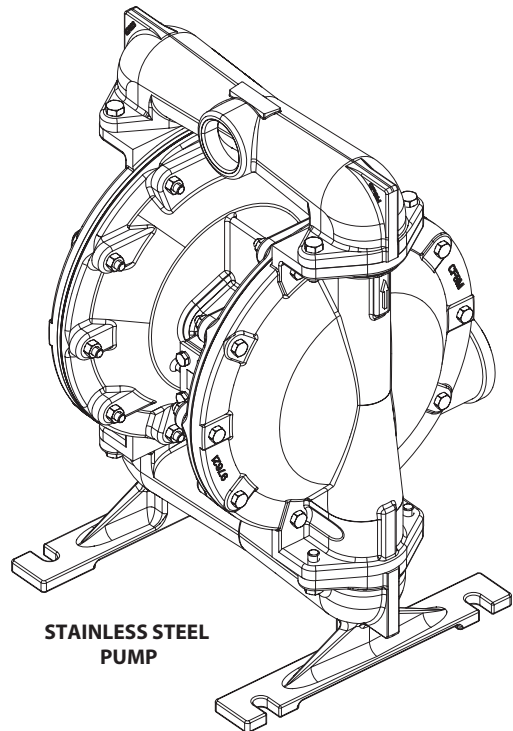

STAINLESS STEEL
PUMP

Figure 1

INGERSOLL RAND COMPANY INC

209 NORTH MAIN STREET - BRYAN, OHIO 43506

☎ (800) 495-0276 • FAX (800) 892-6276

© 2021

CCN 81660219

arozone.com

ARO

IR Ingersoll Rand®

MODEL DESCRIPTION CHART

6661 X X - X X X - C

CENTER BODY MATERIAL

- 5 - Aluminum, NPTF
- 6 - Cast Iron, NPTF
- 7 - Aluminum, BSP
- 8 - Cast Iron, BSP

FLUID CAP / MANIFOLD MATERIAL

- (Steel Hardware)
- 0 - Aluminum
 - 1 - Stainless Steel
 - 2 - Cast Iron
- (Stainless Steel Hardware)
- A - Aluminum
 - B - Stainless Steel
 - C - Cast Iron

Seat Material

- 1 - Aluminum
- 2 - 316 Stainless Steel
- 3 - Polypropylene
- 4 - PVDF
- 5 - Carbon Steel
- 8 - 440 Stainless Steel

Ball Material

- 2 - Nitrile
- 3 - Viton
- 4 - PTFE
- 6 - Acetal
- 8 - Polyurethane
- A - Stainless Steel
- C - Hytrel
- E - Santoprene

Diaphragm Material

- 1 - Neoprene
- 2 - Nitrile
- 3 - Viton
- 4 - PTFE / Santoprene
- 6 - Composite PTFE
- 9 - Hytrel
- B - Santoprene

FLUID SECTION SERVICE KIT SELECTION

EXAMPLE: MODEL # 666150-361-C
 Fluid Section Service Kit # 637124-61

6661XX- X X X - C
 637124- X X
 Ball └─┬─┘ Diaphragm

OPERATING AND SAFETY PRECAUTIONS

READ, UNDERSTAND, AND FOLLOW THIS INFORMATION TO AVOID INJURY AND PROPERTY DAMAGE.



⚠ WARNING EXCESSIVE AIR PRESSURE. Can cause personal injury, pump damage or property damage.

- Do not exceed the maximum inlet air pressure as stated on the pump model plate.
- Be sure material hoses and other components are able to withstand fluid pressures developed by this pump. Check all hoses for damage or wear. Be certain dispensing device is clean and in proper working condition.

⚠ WARNING STATIC SPARK. Can cause explosion resulting in severe injury or death. Ground pump and pumping system.

- Sparks can ignite flammable material and vapors.
- The pumping system and object being sprayed must be grounded when it is pumping, flushing, recirculating or spraying flammable materials such as paints, solvents, lacquers, etc. or used in a location where surrounding atmosphere is conducive to spontaneous combustion. Ground the dispensing valve or device, containers, hoses and any object to which material is being pumped.
- Use the pump grounding screw terminal provided. Use ARO® part no. 66885-1 ground kit or connect a suitable ground wire (12 ga. minimum) to a good earth ground source.
- Secure pump, connections and all contact points to avoid vibration and generation of contact or static spark.
- Consult local building codes and electrical codes for specific grounding requirements.
- Aftergrounding, periodically verify continuity of electrical path to ground. Test with an ohmmeter from each component (e.g., hoses, pump, clamps, container, spray gun, etc.) to ground to ensure continuity. Ohmmeter should show 0.1 ohms or less.
- Submerge the outlet hose end, dispensing valve or device in the material being dispensed if possible. (Avoid free streaming of material being dispensed.)
- Use hoses incorporating a static wire.
- Use proper ventilation.
- Keep inflammables away from heat, open flames and sparks.
- Keep containers closed when not in use.
- **⚠ WARNING** Pump exhaust may contain contaminants. Can cause severe injury. Pipe exhaust away from work area and personnel.
- In the event of a diaphragm rupture, material can be forced out of the air exhaust muffler.
- Pipe the exhaust to a safe remote location when pumping hazardous or inflammable materials.
- Use a grounded 3/4" minimum ID hose between the pump and the muffler.

⚠ WARNING HAZARDOUS PRESSURE. Can result in serious injury or property damage. Do not service or clean pump, hoses or dispensing valve while the system is pressurized.

- Disconnect air supply line and relieve pressure from the system by opening dispensing valve or device and / or carefully and slowly loosening and removing outlet hose or piping from pump.

⚠ WARNING HAZARDOUS MATERIALS. Can cause serious injury or property damage. Do not attempt to return a pump to the factory or service center that contains hazardous material. Safe handling practices must comply with local and national laws and safety code requirements.

- Obtain Material Safety Data Sheets on all materials from the supplier for proper handling instructions. Obtain Material Safety Data Sheets on all materials from the supplier for proper handling instructions.

⚠ WARNING EXPLOSION HAZARD. Models containing aluminum wetted parts cannot be used with 1,1,1-trichloroethane, methylene chloride or other halogenated hydrocarbon solvents which may react and explode.

- Check pump motor section, fluid caps, manifolds and all wetted parts to assure compatibility before using with solvents of this type.

⚠ CAUTION Verify the chemical compatibility of the pump wetted parts and the substance being pumped, flushed or recirculated. Chemical compatibility may change with temperature and concentration of the chemical(s) within the substances being pumped, flushed or circulated. For specific fluid compatibility, consult the chemical manufacturer.

⚠ CAUTION Maximum temperatures are based on mechanical stress only. Certain chemicals will significantly reduce maximum safe operating temperature. Consult the chemical manufacturer for chemical compatibility and temperature limits. Refer to PUMP DATA on page 1 of this manual.

⚠ CAUTION Be certain all operators of this equipment have been trained for safe working practices, understand it's limitations, and wear safety goggles / equipment when required.

⚠ CAUTION Do not use the pump for the structural support of the piping system. Be certain the system components are properly supported to prevent stress on the pump parts.

- Suction and discharge connections should be flexible connections (such as hose), not rigid piped, and should be compatible with the substance being pumped.

⚠ CAUTION Prevent unnecessary damage to the pump.

Do not allow pump to operate when out of material for long periods of time.

- Disconnect air line from pump when system sits idle for long periods of time.

⚠ CAUTION Use only genuine ARO replacement parts to assure compatible pressure rating and longest service life.

NOTICE Replacement warning labels are available upon request: "Static Spark" (93616-1) & "Diaphragm Rupture" (93122).

⚠ WARNING = Hazards or unsafe practices which could result in severe personal injury, death or substantial property damage.

⚠ CAUTION = Hazards or unsafe practices which could result in minor personal injury, product or property damage.

NOTICE = Important installation, operation or maintenance information.

GENERAL DESCRIPTION

The ARO diaphragm pump offers high volume delivery even at low air pressure and a broad range of material compatibility options available. Refer to the model and option chart. ARO pumps feature stall resistant design, modular air motor / fluid sections. Air operated double diaphragm pumps utilize a pressure differential in the air chambers to alternately create suction and positive fluid pressure in the fluid chambers, valve checks ensure a positive flow of fluid. Pump cycling will begin as air pressure is applied and it will continue to pump and keep up with the demand. It will build and maintain line pressure and will stop cycling once maximum line pressure is reached (dispensing device closed) and will resume pumping as needed.

AIR AND LUBE REQUIREMENTS

EXCESSIVE AIR PRESSURE. Can cause personal injury, pump damage or property damage.

- A filter capable of filtering out particles larger than 50 microns should be used on the air supply. There is no lubrication required other than the "O" ring lubricant which is applied during assembly or repair.
- If lubricated air is present, make sure that it is compatible with the "O" rings and seals in the air motor section of the pump.

OPERATING INSTRUCTIONS

- Always flush the pump with a solvent compatible with the material being pumped if the material being pumped is subject to "setting up" when not in use for a period of time.
- Disconnect the air supply from the pump if it is to be inactive for a few hours.
- The outlet material volume is governed not only by the air supply, but also by the material supply available at the inlet. The material supply tubing should not be too small or restrictive. Be sure not to use hose which might collapse.
- When the diaphragm pump is used in a forced-feed (flooded inlet) situation, it is recommended that a "Check Valve" be installed at the air inlet.
- Secure the diaphragm pump legs to a suitable surface to ensure against damage by vibration.

MAINTENANCE

Refer to the part views and descriptions as provided on pages 5 through 9 for parts identification and service kit information.

- Certain ARO "Smart Parts" are indicated which should be available for fast repair and reduction of down time.
- Service kits are divided to service two separate diaphragm pump functions: 1. AIR SECTION, 2. FLUID SECTION. The FLUID SECTION is divided further to match typical part MATERIAL OPTIONS.
- Provide a clean work surface to protect sensitive internal moving parts from contamination from dirt and foreign matter during service disassembly and reassembly.
- Keep good records of service activity and include pump in preventive maintenance program.
- Before disassembling, empty captured material in the outlet manifold by turning the pump upside down to drain material from the pump.

FLUID SECTION DISASSEMBLY

1. Remove top manifold(s).
2. Remove (22) balls, (19) "O" rings and (21) seats.
3. Remove (15) fluid caps.

NOTE: Only PTFE diaphragm models use a primary diaphragm (7) and a backup diaphragm (8). Refer to the auxiliary view in the Fluid Section illustration.

For 6661XX-XX6-C:

4. Remove (7) diaphragm, (5) washers and (30) shims.

For other models:

4. Remove the (14) screws, (6) washers, (7) or (7 / 8) diaphragms and (5) washers.
5. Remove (3) "O" rings.

NOTE: Do not scratch or mar the surface of (1) diaphragm rod.

FLUID SECTION REASSEMBLY

- Reassemble in reverse order.
- Clean and inspect all parts. Replace worn or damaged parts with new parts as required.
- Lubricate (1) diaphragm rod and (2) "O" ring with Key-Lube "O" ring lube.
- Install (2) "O" ring on (1) diaphragm rod.

For 6661XX-XX6-C:

- Attach a regulated airline to the pump inlet; gradually increasing the air pressure (6-8 psi) to check which side of the pump with air blowing out, and then shut down the air supplier.
- Fasten (7) diaphragm with (5) washer into (1) diaphragm rod, and insert them into (101) Center body from the chamber identified with blowing air in the previous step.
- Install (15) fluid cap.
- Thread the other side of (7) diaphragm with (5) washer into (1) diaphragm rod, but do not tighten it.
- Record the angle for the misalignment between (7) diaphragm hole and (101) center body holes, then unthread the (7) diaphragm and place proper Qty. of (30) shims between (5) washer and (1) diaphragm rod.
- Attach a regulated airline to the pump inlet, gradually increasing the air pressure (6-8 psi) until the diaphragm shift to the other site, shut down the air supply.
- Install the second (15) fluid cap.

NOTE: For details, refer to service kits manual 48495949.

For other models:

- Be certain (7) or (7 / 8) diaphragm(s) align properly with (15) fluid caps before making final torque adjustments on bolt and nuts to avoid twisting the diaphragm.
- For models with PTFE diaphragms: Item (8) Santoprene diaphragm is installed with the side marked "AIR SIDE" towards the pump center body. Install the PTFE diaphragm with the side marked "FLUID SIDE" towards the fluid cap.
- Check all torque settings after pump has been re-started and run a while.

PARTS LIST / 66615X-X-C FLUID SECTION

★ 637124-XX Fluid Section Service Kits include: BALLS (see Ball Option, refer to -XX in chart below), DIAPHRAGMS (see Diaphragm Option, refer to -XX in chart below), 93706-1 Key-Lube grease packet, plus items: 2, 3, 9 and 19.

SEAT OPTIONS 6661XX-XXX-C

★ "21"			
-XXX	Seat	Qty	[Mtl]
-1XX	92760	(4)	[A]
-2XX	92776	(4)	[SS]
-3XX	92924	(4)	[P]
-4XX	94514	(4)	[K]
-5XX	95676	(4)	[C]
-8XX	93266	(4)	[SH]

BALL OPTIONS 6661XX-XXX-C

★ "22" (1-1/4" dia.)							
-XXX	Ball	Qty	[Mtl]	-XXX	Ball	Qty	[Mtl]
-X2X	92757-2	(4)	[B]	-XAX	94804	(4)	[SS]
-X3X	92757-3	(4)	[V]	-XCX	92757-C	(4)	[H]
-X4X	92757-4	(4)	[T]	-XEX	92757-A	(4)	[Sp]
-X6X	92757-6	(4)	[D]				
-X8X	92757-8	(4)	[U]				

MATERIAL CODE

[A] = Aluminum
 [B] = Nitrile
 [C] = Carbon Steel
 [CI] = Cast Iron
 [Co] = Copper
 [CP] = Composite PTFE
 [D] = Acetal
 [E] = E.P.R.
 [H] = Hytrel
 [K] = PVDF
 [P] = Polypropylene
 [SH] = Hard Stainless Steel
 [Sp] = Santoprene
 [SS] = Stainless Steel
 [T] = PTFE
 [U] = Polyurethane
 [V] = Viton

DIAPHRAGM OPTIONS 6661XX-XXX-C

-XXX	★ SERVICE KIT -XX = (Ball) -XX = (Diaphragm)	★ "7"			★ "8"			★ "3" (1/16" x 3/4" OD)			★ "19"		
		Diaphragm	[Qty]	[Mtl]	Diaphragm	[Qty]	[Mtl]	"O" Ring	[Qty]	[Mtl]	"O" Ring	[Qty]	[Mtl]
-XX1	637124-X1	92755-1	(2)	[N]	---	---	---	Y325-16	(4)	[B]	Y325-230	(4)	[B]
-XX2	637124-X2	92755-2	(2)	[B]	---	---	---	Y325-16	(4)	[B]	Y325-230	(4)	[B]
-XX3	637124-X3	92755-3	(2)	[V]	---	---	---	Y328-16	(4)	[T]	Y327-230	(4)	[V]
-XX4	637124-X4	94617	(2)	[T]	94616	(2)	[Sp]	Y328-16	(4)	[T]	Y220-230	(4)	[T]
-XX6	48496806	48490064	(2)	[CP]	---	---	---	---	---	---	Y220-230	(4)	[T]
-XX9	637124-X9	94615-9	(2)	[H]	---	---	---	Y328-16	(4)	[T]	Y327-230	(4)	[V]
-XXB	637124-XB	94615-A	(2)	[Sp]	---	---	---	Y328-16	(4)	[T]	92761	(4)	[E]

WETTED PARTS OPTIONS 6661XX-XXX-C

Item	Description (Size)	Qty	Aluminum 6661X0-X, 6661XA-X			Stainless Steel 6661X1-X, 6661XB-X			Cast Iron 6661X2-X, 6661XC-X		
			NPTF		BSP	NPTF		BSP	NPTF		BSP
			Part No.	Part No.	[Mtl]	Part No.	Part No.	[Mtl]	Part No.	Part No.	[Mtl]
15	Fluid Cap	(2)	92750	92750	[A]	97621	97621	[SS]	92778	92778	[CI]
16	Manifold (6661X0, 1X2, 1XA, 1XC)	(2)	92749	92749-1	[A]	-----	-----	---	92777	92777-1	[CI]
60	Inlet Manifold (6661X1, 1XB)	(1)	-----	-----	---	97624	97624-1	[SS]	-----	-----	---
61	Outlet Manifold (6661X1, 1XB)	(1)	-----	-----	---	97623	97623-1	[SS]	-----	-----	---

HARDWARE OPTIONS 6661XX-XXX-C

Item	Description (Size)	Qty	Carbon Steel 6661X0-, 1-, 2-		Stainless Steel 6661XA-, B-, C	
			Part No.	[Mtl]	Part No.	[Mtl]
26	Bolt (3/8" - 16 x 1-1/4")	(8)	Y6-66-C	[C]	Y6-66-T	[SS]
27	Bolt (5/16" - 18 x 2-1/4") (6661X0, 1X2, 1XA, 1XC)	(4)	Y6-510-C	[C]	Y6-510-T	[SS]
29	Nut (5/16" - 18)	(20)	Y12-5-C	[C]	Y12-5-S	[SS]
32	Leg (6661X0, 1X2, 1XA, 1XC)	(2)	92759	[C]	92759-1	[SS]
◆ 59	Bolt (5/16" - 18 x 2") (6661X0-XX6-C)	(16)	47512837001	[C]	47510437001	[SS]
	(6661XB-XX6-C)	(20)	47512837001	[C]	47510437001	[SS]
	(6661X0, 1X2, 1XA, 1XC)	(16)	93608	[C]	Y6-59-T	[SS]
	(6661X1, 1XB)	(20)	93608	[C]	Y6-59-T	[SS]

**637155
ABRASION RESISTANT
CONVERSION KIT**

Includes:
 93266 (4) [SH] Seat
 92757-8 (4) [U] Ball

COMMON PARTS

Item	Description (size in inches)	Qty	Part No.	[Mtl]	Item	Description (Size in inches)	Qty	Part No.	[Mtl]
□ 1	Rod (6661XX-XX6-C) (other models)	(1)	48489819	[C]	★ 9	Washer (0.630" ID)⊗	(2)	93065	[SS]
★ 2	"O" Ring (3/32" x 1" OD)	(1)	Y330-117	[B]	14	Screw (5/8" - 18 x 1-1/2")⊗	(2)	Y5-107-T	[SS]
□ 5	Plate (air side) (6661XX-XX6-C) (Other models)	(2)	48496673	[C]	43	Ground Lug (see page 7)	(1)	93004	[Co]
□ 6	Plate (fluid side)⊗ (models 6661X0 only)	(2)	92752	[C]	30	Shim (6661XX-XX6-C)	(A)	48499875 #	[C]
		(2)	92775	[SS]					
		(2)	92752	[C]					

⊗ The quantity is between 0 to 5, shims are not shown in the exploded view.

□ "Smart Parts" keep these items on hand in addition to the Service Kits for fast repair and reduction of down time.

For service, shim pack 48499339 can be purchased. Refer to service kits manual 48495949 for details.

⊗ For 6661XX-XX6-C, on the fluid side, washer (6), (9) and screw (14) are not needed.

◆ For 6661X1, 1XB legs (32) and Bolt (27) are not needed, Bolt(59) required in 20 quantity.

PARTS LIST / 6661X0, 1X2, 1XA and 1XC FLUID SECTION

COLOR CODE		
Material	Diaphragm Color	Ball Color
Acetal	N / A	Orange
E.P.R.	Blue (-)	Blue (*)
Hytrel	Cream	Cream
Neoprene	Green (-)	Green (*)
Nitrile	Black	Red (*)
Santoprene	Tan*	Tan
PTFE	White	White
Polyurethane	N / A	Red
Viton	Yellow (-)	Yellow (*)
	(-) Stripe	(*) Dot

* See item 8 in inset below.

TORQUE REQUIREMENTS
NOTE: DO NOT OVERTIGHTEN FASTENERS.
(14) Diaphragm screw, 65 - 70 ft lbs (88.1 - 94.9 Nm).
(26) Bolts, 240 - 280 in. lbs (27.1 - 31.6 Nm).
(29) Nuts, 120 - 140 in. lbs (13.6 - 15.8 Nm).

LUBRICATION / SEALANTS
 ☆ Apply Key-Lube to all "O" rings, "U" Cups & mating parts.
 ◆ Apply Loctite 271 to threads.
 :: Apply anti-seize compound to threads and bolt and nut flange heads which contact pump case when using stainless steel fasteners.

**FOR THE AIR MOTOR SECTION
SEE PAGES 8 AND 9**

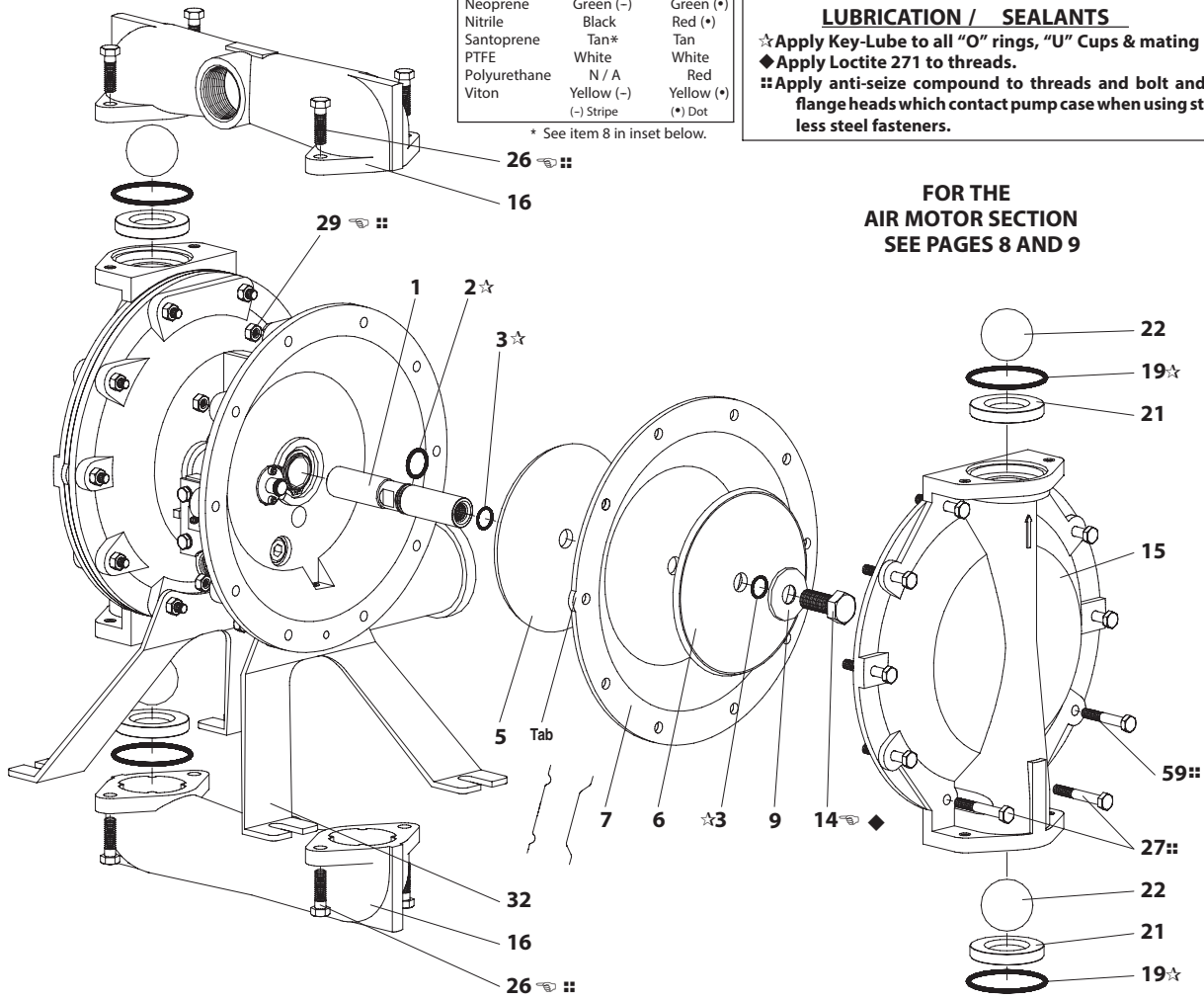
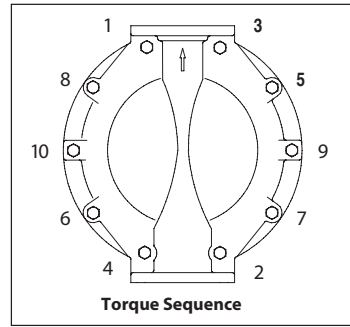
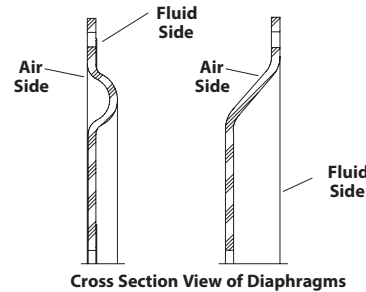
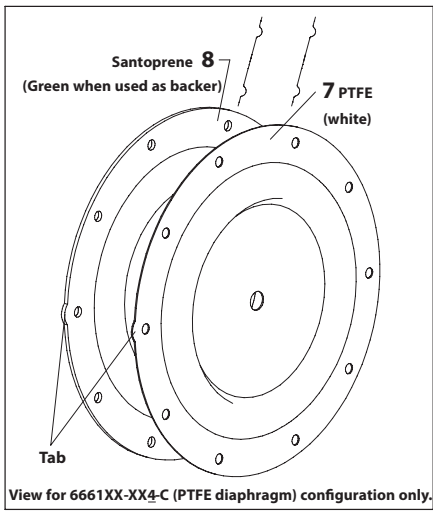

Figure 2



PARTS LIST / 6661X1 and 1XB FLUID SECTION

COLOR CODE		
Material	Diaphragm color	Ball Color
Acetal	N/A	Orange
E.P.R.	Blue(-)	Blue(-)
Hytrel	Cream	Cream
Neoprene	Green(-)	Green(+)
Nitrile	Black	Red(+)
Santoprene	Tan*	Tan
PTFE	White	White
Polyurethane	N/A	Red
Viton	Yellow(-)	Yellow(+)
	(-)Stripe	(+)Dot

*See item 8 in inset below.

TORQUE REQUIREMENTS

NOTE: DO NOT OVERTIGHTEN FASTENERS.

(14) Diaphragm screw, 65 - 70 ft lbs (88.1 - 94.9 Nm.).

(26) Bolts, 240 - 280 in. lbs (27.1 - 31.6 Nm).

(29) Nuts, 120 - 140 in. lbs (13.6 - 15.8 Nm).

LUBRICATION / SEALANTS

★ Apply Key-Lubetoall "O" rings, "U" Cups & mating parts.

◆ Apply Loctite® 271 to threads

☒ Apply anti-seize compound to threads and bolt and nut flange heads which contact pump case when using stainless steel fasteners.

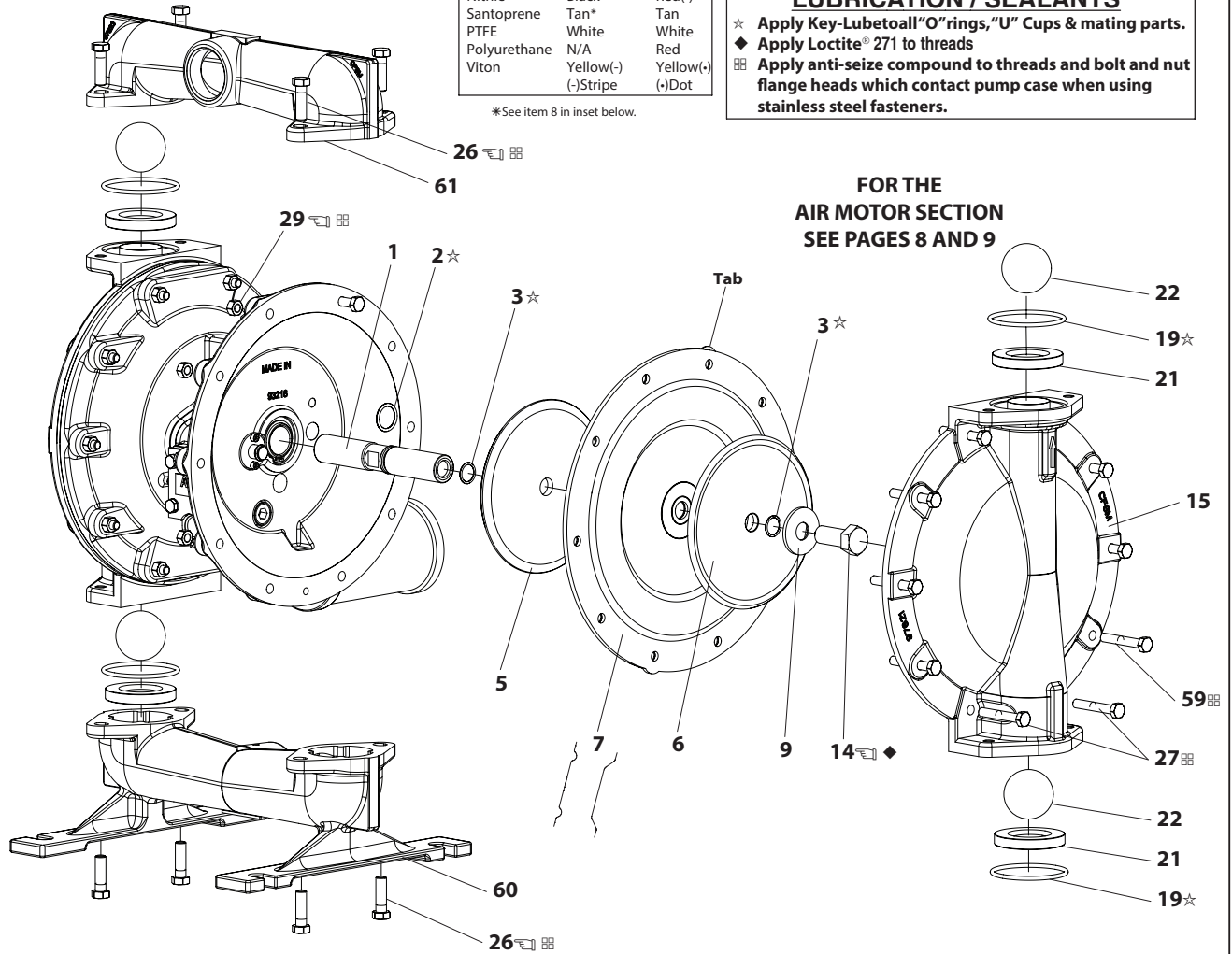

**FOR THE AIR MOTOR SECTION
SEE PAGES 8 AND 9**

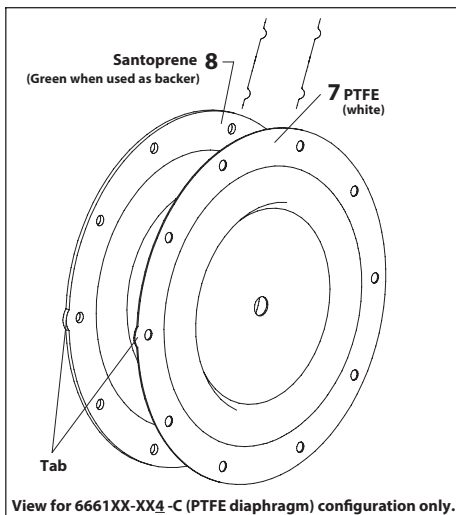
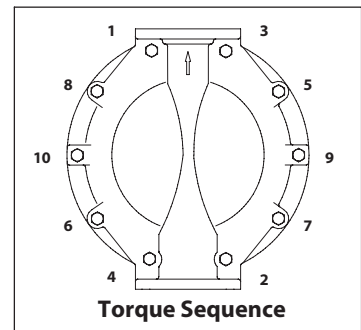
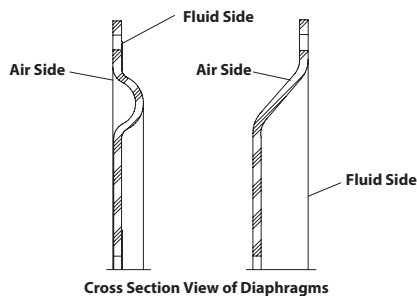

Figure 3



PARTS LIST / 66615X-X-C AIR SECTION

✓ Indicates parts included in 637118-C Air Section Service Kit.

SERVICE KIT NOTE: Service Kit 637118-C is a general repair kit for all 1" and larger ARO diaphragm pump air motors. It contains extra "O" Rings and other parts that may not be needed to service this model.

Item	Description (size)	Qty	Part No.	[Mtl]
101	Motor Body(66615X-X, 66617X-X)	(1)	94744	[A]
	(66616X-X, 66618X-X)	(1)	94742	[CI]
✓ 102	"O" Ring(1/16" x 1-1/4" OD)	(2)	Y325-24	[B]
□ 103	Sleeve	(1)	94528	[D]
✓ 104	Retaining Ring, TruArc (1-5/32" ID)	(2)	Y145-26	[C]
105	Screw / Lockwasher (1/4" - 20 x 5/8") (models 6661X0-X, 6661X1-X, 6661X2-X)	(8)	93860	[C]
	6661XA-X, 6661XB-X, 6661XC-X)	(8)	Y6-42-T	[SS]
106	Lockwasher (1/4") (models 6661XA-X, 6661XB-X, 6661XC-X only)	(8)	Y14-416-T	[SS]
107	Plate	(2)	93707-1	[SS]
✓ 108	Gasket (with notch)	(1)	92878	[B/Ny]
□ 109	Piston	(1)	92011	[D]
✓ 110	"U" Cup (3/16" x 1-3/8" OD)	(1)	Y186-51	[B]
□ 111	Spool (models 66615X-X, 66617X-X)	(1)	92005	[A]
	(models 66616X-X, 66618X-X)	(1)	93047	[C]
□ 112	Washer (1.557" OD)	(5)	92877	[Z]
✓ 113	"O" Ring (small) (1/8" x 1-1/4" OD)	(5)	Y325-214	[B]
✓ 114	"O" Ring (large) (3/32" x 1-9/16" OD)	(6)	Y325-126	[B]

Item	Description (size)	Qty	Part No.	[Mtl]
□ 115	Spacer	(4)	92876	[Z]
□ 116	Spacer	(1)	92006	[Z]
✓ 117	Gasket	(1)	92004	[B/Ny]
118	Pilot Rod	(1)	93309-2	[C]
✓ 119	"O" Ring (1/8" x 3/4" OD)	(4)	93075	[U]
120	Spacer	(3)	115959	[Z]
121	Sleeve Bushing	(2)	98723-2	[Bz]
✓ 122	"O" Ring (3/32" x 9/16" OD)	(2)	94820	[U]
✓ 123	Screw (#8 - 32 x 3/8")	(4)	Y154-41	[C]
126	Pipe Plug (1/2 - 14 PTF x 17/32")	(1)	Y227-5-L	[C]
127	90° Street Elbow (3/4 - 14 NPTF)	(1)	Y43-5-C	[C]
128	Pipe Plug (1/8 - 27 PTF x 1/4")	(1)	Y227-2-L	[C]
195A	Button Head Screw (1/4" - 20 x 1/4")	(2)	94987	[SS]
195B	Button Head Screw (1/4" - 20 x 3/8")	(1)	94987-1	[SS]
201	Muffler	(1)	350-568	
231	Pipe Plug (1/4 - 18 NPTF x 0.41") (models 66616X-X and 66618X-X only)	(2)	Y17-51-S	[SS]
✓	Key-Lube "O" Ring Lubricant	(1)	93706-1	
	10 Pack of Key-Lube		637175	

AIR MOTOR SECTION SERVICE

Service is divided into two parts - 1. Pilot Valve, 2. Major Valve.
GENERAL REASSEMBLY NOTES:

- Air Motor Section Service is continued from Fluid Section repair.
- Inspect and replace old parts with new parts as necessary. Look for deep scratches on metallic surfaces, and nicks or cuts in "O" rings.
- Take precautions to prevent cutting "O" rings upon installation.
- Lubricate "O" rings with Key-Lube.
- Do not over-tighten fasteners, refer to torque specification block on view.
- Make sure to torque all fasteners following restart.

PILOT VALVE DISASSEMBLY

1. Remove (104) retaining ring.
2. Remove (123) screws and (122) "O" rings.
3. Remove (118) piston rod, (121) sleeve bushing, (119) "O" rings and (120) spacers from the (101) motor body.
4. Remove (103) sleeve and (102) "O" rings.

PILOT VALVE REASSEMBLY

1. Replace two (102) "O" rings if worn or damaged and re-install (103) sleeve.
2. Install one of the (121) sleeve bushings, (119) "O" rings, (120) spacers and the remaining (121) bushing.
3. Carefully push (118) pilot rod into bushings etc. and retain on each end with the two (122) "O" rings, retain with (123) screws.
4. Replace (104) retaining rings.

MATERIAL CODE

[A] = Aluminum	[CI] = Cast Iron	[SS] = Stainless Steel
[B] = Nitrile	[D] = Acetal	[U] = Polyurethane
[Bz] = Bronze	[Ny] = Nylon	[Z] = Zinc
[C] = Carbon Steel		

MAJOR VALVE DISASSEMBLY

1. Remove (107) plate (or leg depending on model), (108 and 117) gaskets.
2. On the side opposite the air inlet, push on the inner diameter of (111) spool. This will force the (109) piston out. Continue pushing the (111) spool and remove. Check for scratches and gouges.
3. Reach into the air section (exhaust side) and remove (116) spacer, (115) spacers, (113) "O" rings, (114) "O" rings, (112) washers, etc. Check for damaged "O" rings.

MAJOR VALVE REASSEMBLY

1. Replace (112) washer, (114) "O" ring and (113) "O" ring onto (115) spacer and insert etc.
- NOTE: Be careful to orient spacer legs away from blocking internal ports.**
2. Lubricate and carefully insert (111) spool.
 3. Install (117) gasket and (107).
 4. Lubricate and install (110) packing cup and insert (109) piston into (air inlet side) cavity, the (110) packing cup lips should point outward.
 5. Install (108) gasket and (107).

PARTS LIST / 66615X-X-C AIR SECTION

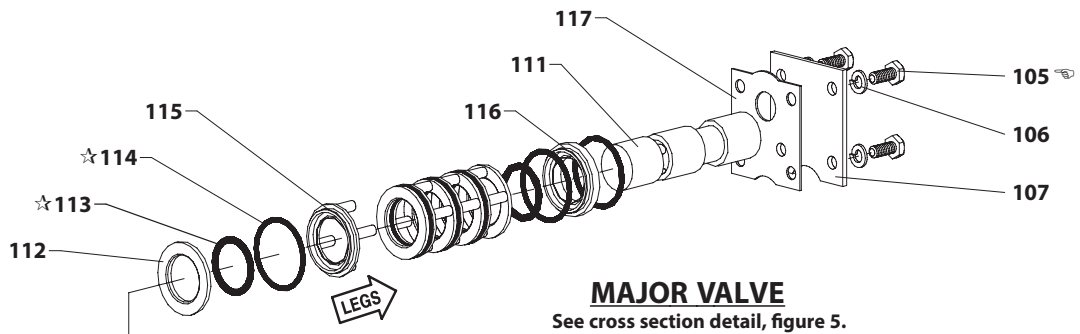

MAJOR VALVE

See cross section detail, figure 5.

IMPORTANT
BE CERTAIN TO ORIENT (115) SPACER LEGS AWAY FROM BLOCKING INTERNAL PORTS WHEN REASSEMBLING AIR SECTION.

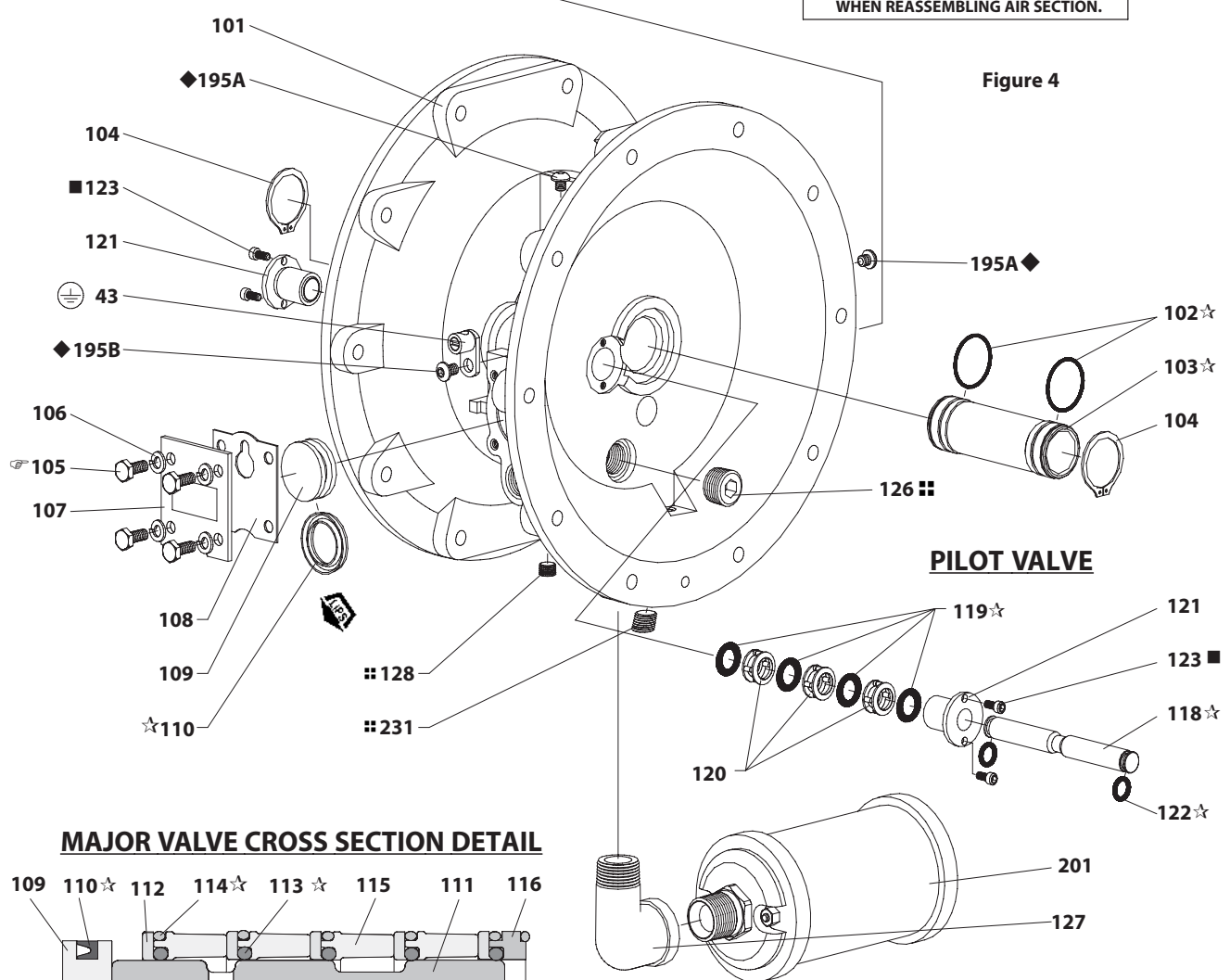

Figure 4

PILOT VALVE

MAJOR VALVE CROSS SECTION DETAIL

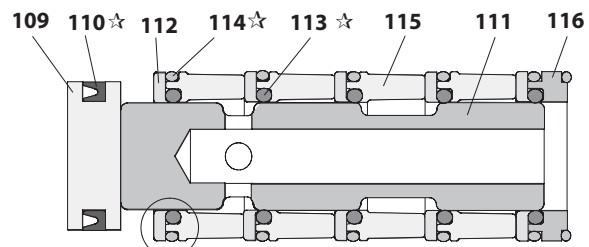

Figure 5

TORQUE REQUIREMENTS
NOTE: DO NOT OVERTIGHTEN FASTENERS.
(105) 40 - 50 in. lbs (4.5 - 5.6 Nm).

LUBRICATION / SEALANTS

- ☆ Apply Key-Lube to all "O" rings, "U" Cups & mating parts.
- Apply Loctite 262 to threads.
- ◆ Apply Loctite 271 to threads.
- ⦿ Apply Loctite 572 to threads.

TROUBLE SHOOTING

Product discharged from exhaust outlet.

- Check for diaphragm rupture.
- Check tightness of (14) diaphragm screw.

Air bubbles in product discharge.

- Check connections of suction plumbing.
- Check "O" rings between intake manifold and fluid caps.
- Check tightness of (14) diaphragm screw.

Low output volume, erratic flow, or no flow.

- Check air supply.
- Check for plugged outlet hose.
- Check for kinked (restrictive) outlet material hose.
- Check for kinked (restrictive) or collapsed inlet material hose.
- Check for pump cavitation - suction pipe should be sized at least as large as the inlet thread diameter of the pump for proper flow if high viscosity fluids are being pumped. Suction hose must be a non-collapsing type, capable of pulling a high vacuum.
- Check all joints on the inlet manifolds and suction connections. These must be air tight.
- Inspect the pump for solid objects lodged in the diaphragm chamber or the seat area.

DIMENSIONAL DATA - 6661X0, 1X2, 1XA and 1XC

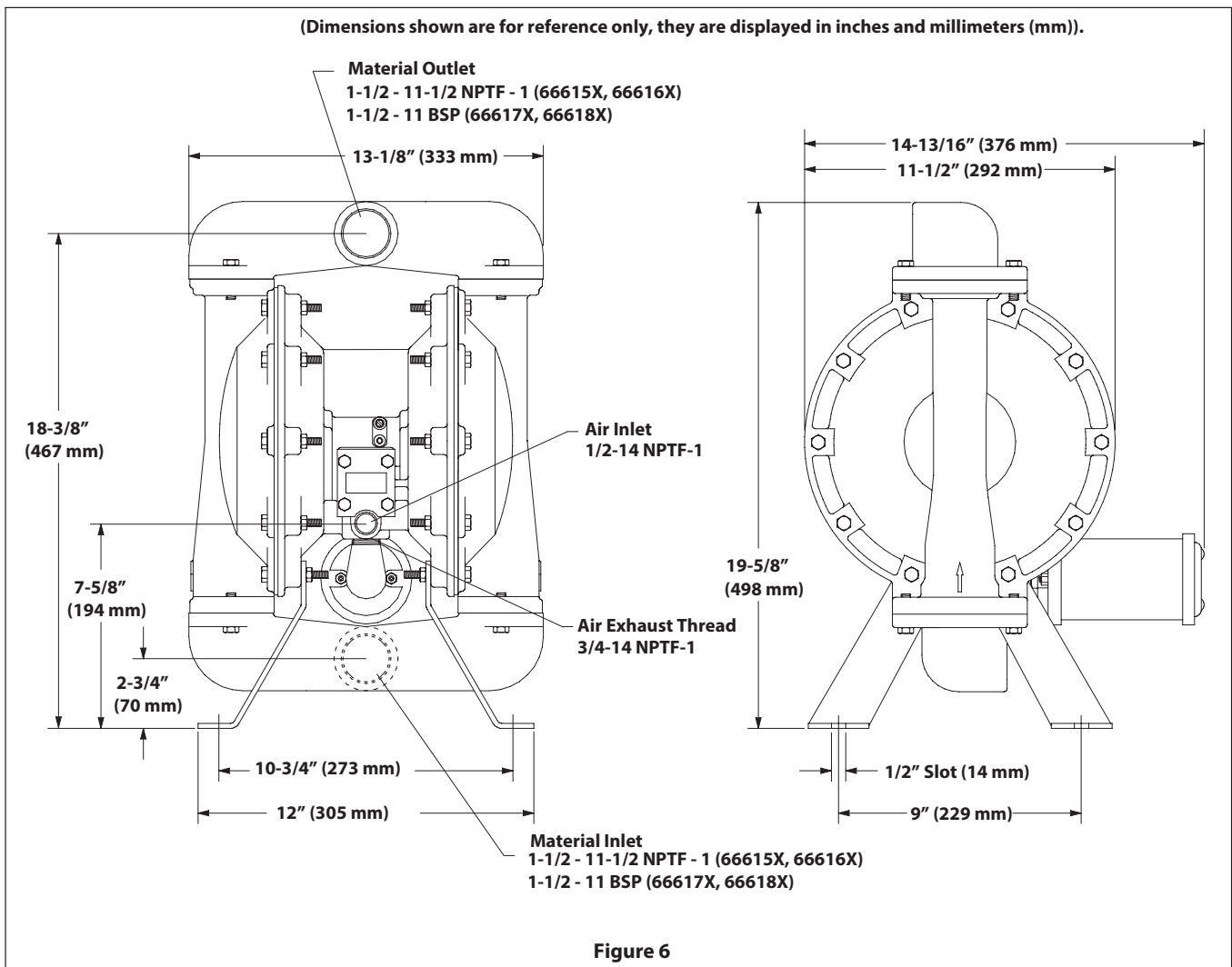

DIMENSIONAL DATA - 6661X1 and 1XB

(Dimensions shown are for reference only, they are displayed in inches and millimeters (mm)).

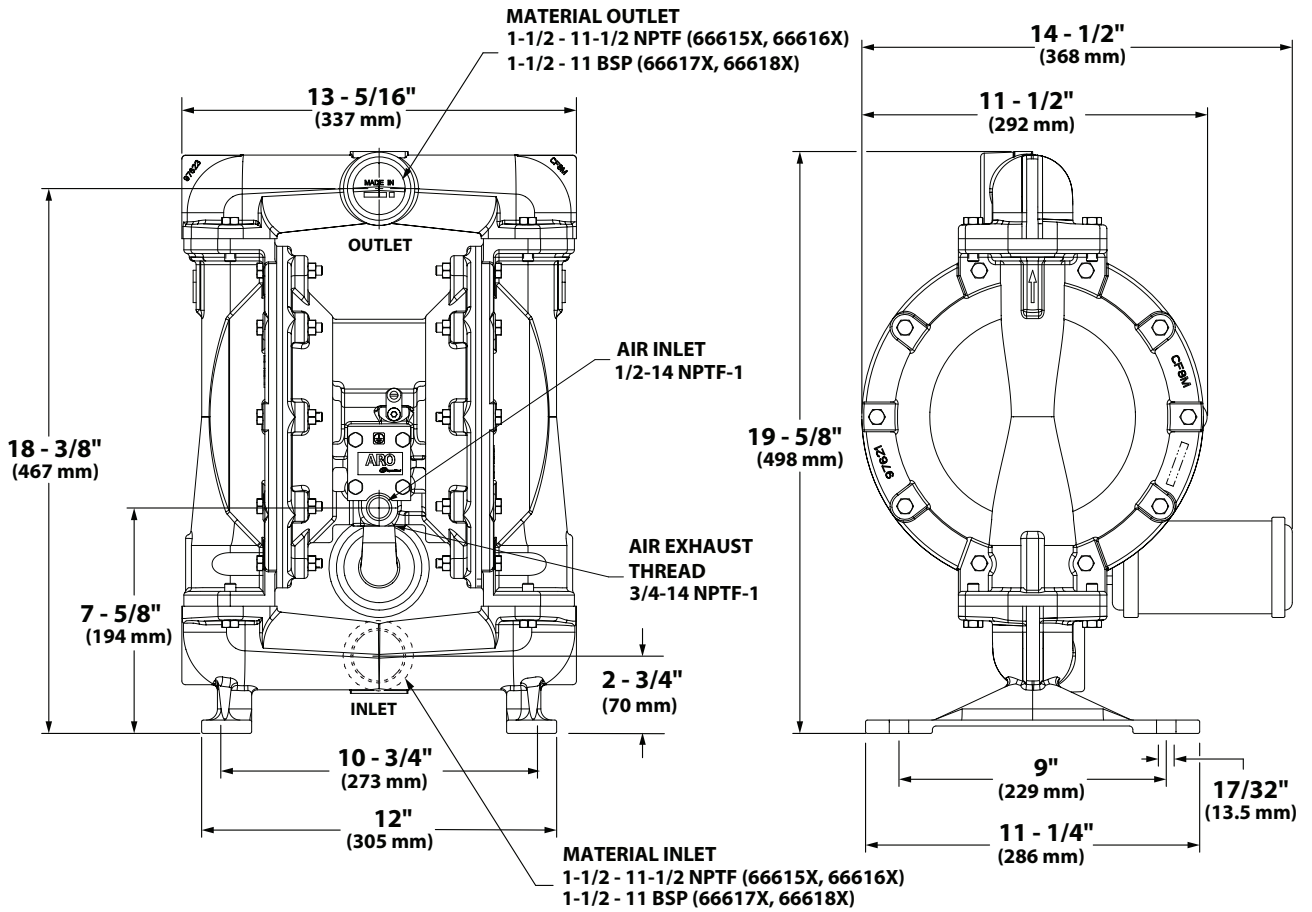

Figure 7

