

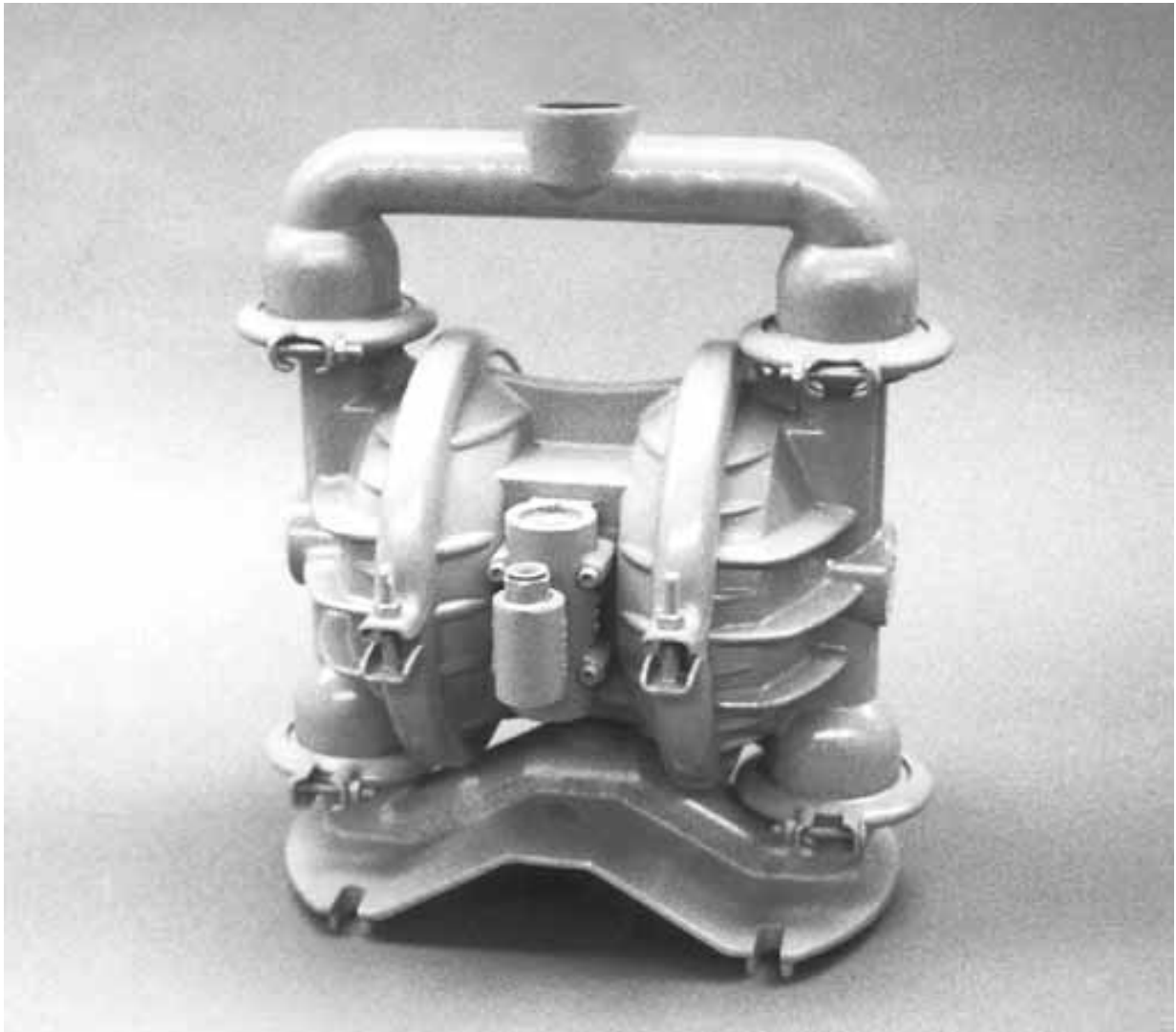

MODEL: DJ T 4

Assembly, Installation and Operation Manual



DJ PUMP DESIGNATION SYSTEM

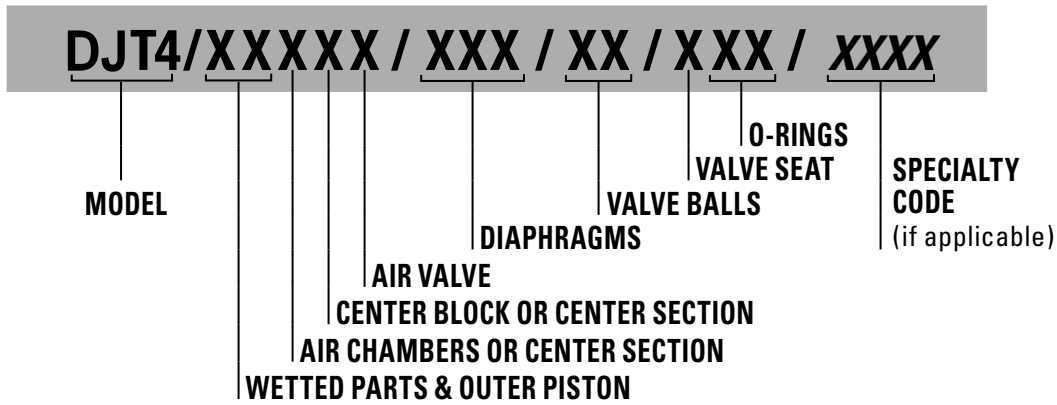

MATERIAL CODES

MODEL

DJT4 = 38 MM (1-1/2")

WETTED PARTS & OUTER PISTON

AA = ALUMINUM / ALUMINUM
 WW = CAST IRON / CAST IRON
 WM = CAST IRON / MILD STEEL

AIR CHAMBER / CENTER SECTION

A = ALUMINUM
 M = MILD STEEL
 P = POLYPROPYLENE

CENTER BLOCK / CENTER SECTION

A = ALUMINUM
 P = POLYPROPYLENE

AIR VALVE

B = BRASS

DIAPHRAGMS

BNS = BUNA-N (Red Dot)
 BNU = BUNA-N, ULTRA-FLEX (Red Dot)
 EPS = EPDM (Blue Dot)
 EPU = EPDM, ULTRA-FLEX (Blue Dot)
 FSS = SANIFLEX [Hytrel (Cream)]
 NES = NEOPRENE (Green Dot)
 NEU = NEOPRENE, ULTRA-FLEX (Green Dot)
 PUS = POLYURETHANE (Clear)
 TEU = PTFE W/EPDM BACK-UP (White)
 TNU = PTFE W/NEOPRENE BACK-UP (White)
 TSU = PTFE W/SANIFLEX BACK-UP (White)
 VTS = VITON (White Dot)
 VTU = VITON, ULTRA-FLEX (White Dot)
 WFS = SANTOPRENE (Orange Dot)

VALVE BALL

BN = BUNA-N (Red Dot)
 EP = EPDM (Blue Dot)
 FS = SANIFLEX [Hytrel (Cream)]
 NE = NEOPRENE (Green Dot)
 PU = POLYURETHANE (Brown)
 TF = PTFE (White)
 VT = VITON (White Dot)
 WF = SANTOPRENE (Orange Dot)

VALVE SEAT

A = ALUMINUM
 BN = BUNA-N (Red Dot)
 EP = EPDM (Blue Dot)
 FS = SANIFLEX [Hytrel (Cream)]
 H = ALLOY C
 M = MILD STEEL
 NE = NEOPRENE (Green Dot)
 PU = POLYURETHANE (Brown)
 S = STAINLESS STEEL
 VT = VITON (White Dot)
 WF = SANTOPRENE (Orange Dot)

No valve seat o-ring required.

VALVE SEAT O-RING

FS = FLUORO-SEAL
 TF = PTFE (White)

SPECIALTY CODES

0014 BSPT



THE DJ PUMP - HOW IT WORKS

The diaphragm pump is an air-operated, positive displacement, self-priming pump. These drawings show the flow pattern through the pump upon its initial stroke. It is assumed the pump has no fluid in it prior to its initial stroke.

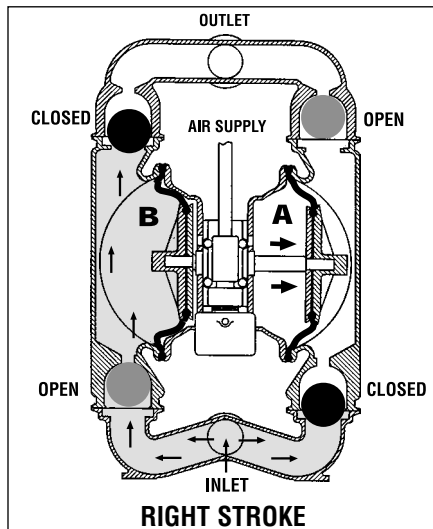

FIGURE 1 The air valve directs pressurized air to the back side of diaphragm A. The compressed air is applied directly to the liquid column separated by elastomeric diaphragms. The diaphragm acts as a separation membrane between the compressed air and liquid, balancing the load and removing mechanical stress from the diaphragm. The compressed air moves the diaphragm away from the center block of the pump. The opposite diaphragm is pulled in by the shaft connected to the pressurized diaphragm. Diaphragm B is on its suction stroke; air behind the diaphragm has been forced out to the atmosphere through the exhaust port of the pump. The movement of diaphragm B toward the center block of the pump creates a vacuum within chamber B. Atmospheric pressure forces fluid into the inlet manifold forcing the inlet valve ball off its seat. Liquid is free to move past the inlet valve ball and fill the liquid chamber (see shaded area).

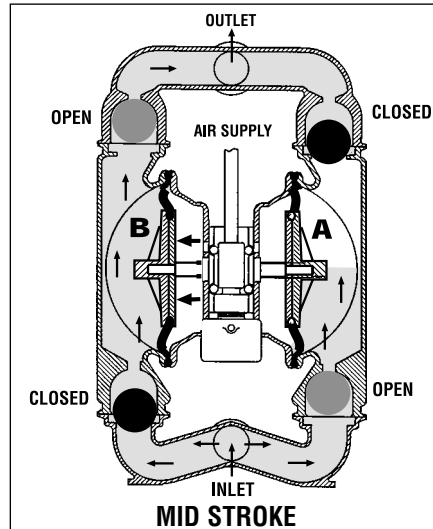

FIGURE 2 When the pressurized diaphragm, diaphragm A, reaches the limit of its discharge stroke, the air valve redirects pressurized air to the back side of diaphragm B. The pressurized air forces diaphragm B away from the center block while pulling diaphragm A to the center block. Diaphragm B is now on its discharge stroke. Diaphragm B forces the inlet valve ball onto its seat due to the hydraulic forces developed in the liquid chamber and manifold of the pump. These same hydraulic forces lift the discharge valve ball off its seat, while the opposite discharge valve ball is forced onto its seat, forcing fluid to flow through the pump discharge. The movement of diaphragm A toward the center block of the pump creates a vacuum within liquid chamber A. Atmospheric pressure forces fluid into the inlet manifold of the pump. The inlet valve ball is forced off its seat allowing the fluid being pumped to fill the liquid chamber.

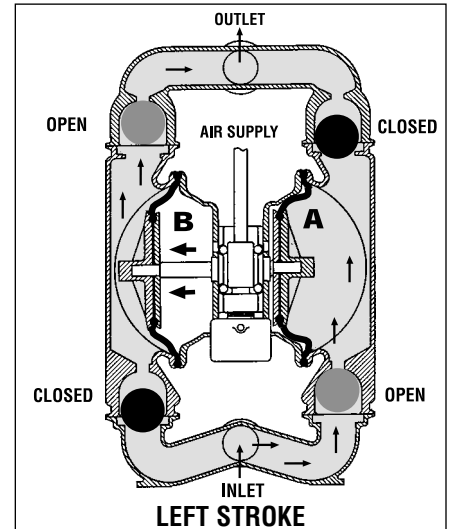

FIGURE 3 At completion of the stroke, the air valve again redirects air to the back side of diaphragm A, which starts diaphragm B on its exhaust stroke. As the pump reaches its original starting point, each diaphragm has gone through one exhaust and one discharge stroke. This constitutes one complete pumping cycle. The pump may take several cycles to completely prime depending on the conditions of the application.



MODEL DJT4 METAL

CAUTIONS - READ FIRST



TEMPERATURE LIMITS:

Polypropylene	0°C to 79°C	32°F to 175°F
Neoprene	-17.8°C to 93.3°C	0°F to 200°F
Buna-N	-12.2°C to 82.2°C	10°F to 180°F
EPDM	-51.1°C to 137.8°C	-60°F to 280°F
Viton	-40°C to 176.7°C	-40°F to 350°F
Santoprene	-40°C to 107.2°C	-40°F to 225°F
Polyurethane	-12.2°C to 65.6°C	10°F to 150°F
Hytrel	-28.9°C to 104.4°C	-20°F to 220°F
PTFE	4.4°C to 148.9°C	40°F to 300°F



CAUTION: When choosing pump materials, be sure to check the temperature limits for all wetted components. Example: Viton has a maximum limit of 176.7°C (350°F) but polypropylene has a maximum limit of only 79°C (175°F).



CAUTION: Maximum temperature limits are based upon mechanical stress only. Certain chemicals will significantly reduce maximum safe operating temperatures. Consult engineering guide for chemical compatibility and temperature limits.



CAUTION: Always wear safety glasses when operating pump. If diaphragm rupture occurs, material being pumped may be forced out air exhaust.



WARNING: Prevention of static sparking — If static sparking occurs, fire or explosion could result. Pump, valves, and containers must be properly grounded when handling flammable fluids and whenever discharge of static electricity is a hazard.



CAUTION: Do not exceed 8.6 Bar (125 psig) air supply pressure. (3.4 Bar [50 psig] for UL models.)



CAUTION: Before any maintenance or repair is attempted, the compressed air line to the pump should be disconnected and all air pressure allowed to bleed from pump. Disconnect all intake, discharge and air lines. Drain the pump by turning it upside down and allowing any fluid to flow into a suitable container.



CAUTION: Blow out air line for 10 to 20 seconds before attaching to pump to make sure all pipe line debris is clear. Use an in-line air filter. A 5µ (micron) air filter is recommended.



NOTE: Tighten clamp bands and retainers prior to installation. Fittings may loosen during transportation.



NOTE: When installing Teflon diaphragms, it is important to tighten outer pistons simultaneously (turning in opposite directions) to ensure tight fit.



NOTE: Before starting disassembly, mark a line from each liquid chamber to its corresponding air chamber. This line will assist in proper alignment during reassembly.



CAUTION: Verify the chemical compatibility of the process and cleaning fluid to the pump's component materials in the Chemical Resistance Guide.



CAUTION: When removing the end cap using compressed air, the air valve end cap may come out with considerable force. Hand protection such as a padded glove or rag should be used to capture the end cap.



CAUTION: Only explosion proof (NEMA 7) solenoid valves should be used in areas where explosion proof equipment is required.



NOTE: All non lube-free air-operated pumps must be lubricated. Wilden suggests an arctic 5 weight oil (ISO grade 15). Do not over-lubricate pump. Over-lubrication will reduce pump performance.



NOTE: UL-listed pumps must not exceed 3.4 Bar (50 psig) air supply pressure.



CAUTION: Do not lubricate lube-free pumps.



Performance

DJT4

Height.....442 mm (17.4")
 Width.....391 mm (15.4")
 Depth.....285 mm (11.2")
 Ship Weight.....Aluminum 17.5 kg (38 lbs.)
 Stainless Steel 26.2 kg (57 lbs.)
 Cast Iron 26.2 kg (57 lbs.)
 Hastelloy 26.2 kg (57 lbs.)
 Air Inlet13 mm (½")
 Inlet.....38 mm (1½")
 Outlet32 mm (1¼")
 Suction Lift.....5.49 m (18')
 8.53 m (28')

Displacement per

Stroke 1.02 l (0.27 gal.)
 Max. Flow Rate.....288 lpm (76 gpm)
 Max. Size Solids.....¾" (4.8 mm)
 Displacement per stroke was calculated at 4.8 Bar (70 psig) air inlet pressure against a 2 Bar (30 psig) head pressure.

Example: To pump 113.6 lpm (30 gpm) against a discharge pressure head of 2.7 Bar (40 psig) requires 4.1 Bar (60 psig) and 25.5 Nm³/h (15 scfm) air consumption. (See dot on chart.)

Caution: Do not exceed 8.6 Bar (125 psig) air supply pressure.

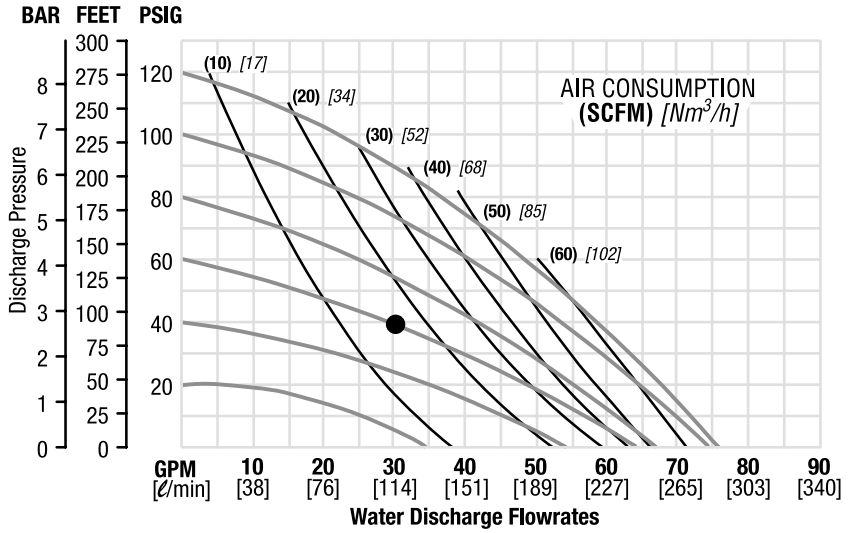

Flow rates indicated on chart were determined by pumping water.

For optimum life and performance, pumps should be specified so that daily operation parameters will fall in the center of the pump performance curve.

Dimensional Drawings for DJT4 Pumps

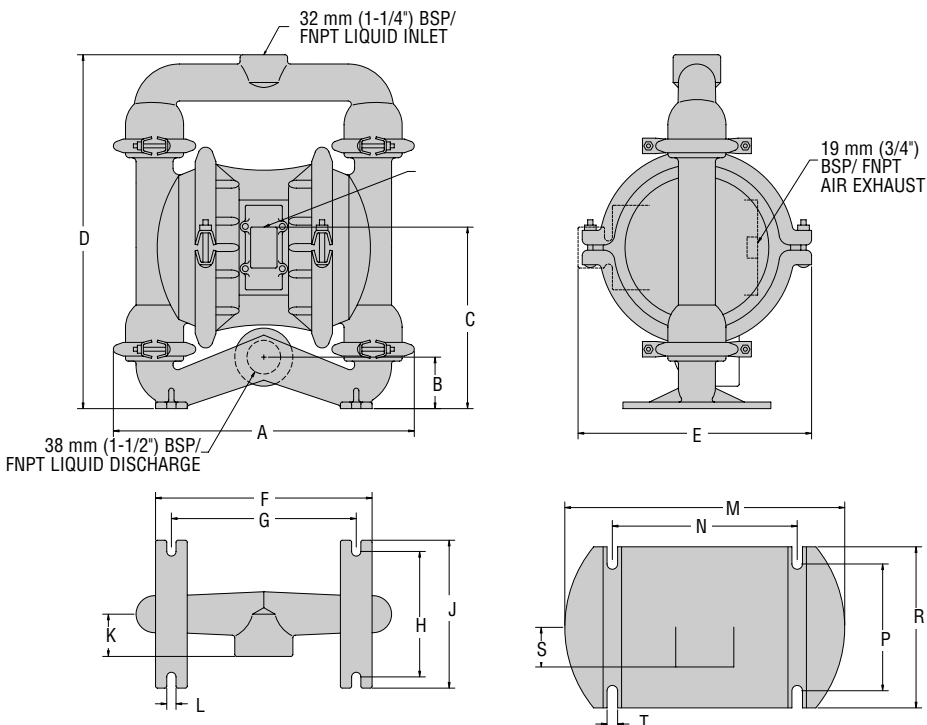

DIMENSIONS – DJT4 (METAL)		
ITEM	METRIC (mm)	STANDARD (inch)
A	391	15.4
B	63	2.5
C	219	8.6
D	442	17.4
E	285	11.2
F	262	10.3
G	224	8.8
H	152	6.0
J	178	7.0
K	67	2.6
L	11	0.4

BSP threads available.



SUGGESTED INSTALLATION

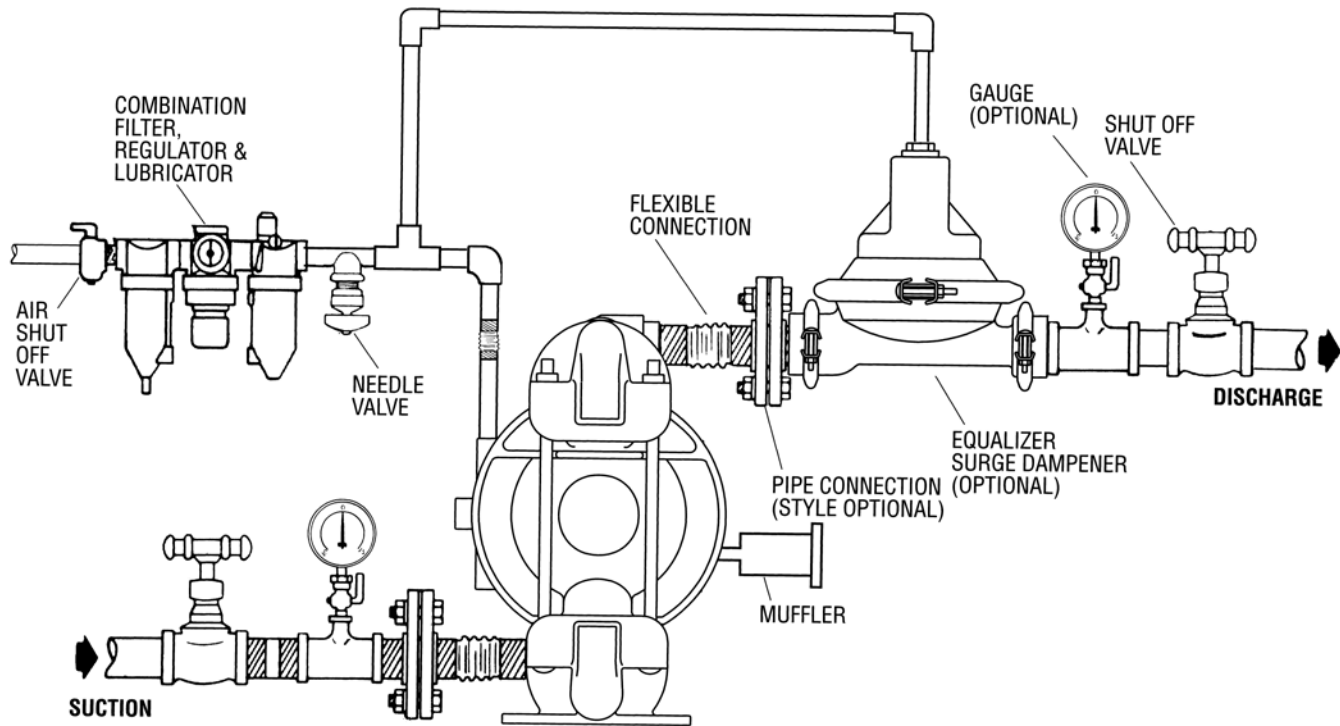

NOTE: In the event of a power failure, the shutoff valve should be closed, if the restarting of the pump is not desirable once power is regained.

AIR OPERATED PUMPS: To stop the pump from operating in an emergency situation, simply close the “shut-off” valve (user supplied) installed in the air supply line. A properly functioning valve will stop the air supply to the pump, therefore stopping output. This “shut-off” valve should be located far enough away from the pumping equipment such that it can be reached safely in an emergency situation.

SUGGESTED OPERATION AND MAINTENANCE INSTRUCTIONS

OPERATION: Pump discharge rate can be controlled by limiting the volume and/or pressure of the air supply to the pump (preferred method). An air regulator is used to regulate air pressure. A needle valve is used to regulate volume. Pump discharge rate can also be controlled by throttling the pump discharge by partially closing a valve in the discharge line of the pump. This action increases friction loss which reduces flow rate. This is useful when the need exists to control the pump from a remote location. When the pump discharge pressure equals or exceeds the air supply pressure, the pump will stop; no bypass or pressure relief valve is needed, and pump damage will not occur. The pump has reached a “deadhead” situation and can be restarted by reducing the fluid discharge pressure or increasing the air inlet pressure. The Wilden T2 pump runs solely on compressed air and does not generate heat, therefore your process fluid temperature will not be affected.

RECORDS: When service is required, a record should be made of all necessary repairs and replacements. Over a period of time, such records can become a valuable tool for predicting and preventing future maintenance problems and unscheduled downtime. In addition, accurate records make it possible to identify pumps that are poorly suited to their applications.

MAINTENANCE AND INSPECTIONS: Since each application is unique, maintenance schedules may be different for every pump. Frequency of use, line pressure, viscosity and abrasiveness of process fluid all affect the parts life of a Wilden pump. Periodic inspections have been found to offer the best means for preventing unscheduled pump downtime. Personnel familiar with the pump’s construction and service should be informed of any abnormalities that are detected during operation.



EXPLODED VIEWS FOR DJT4 PUMPS

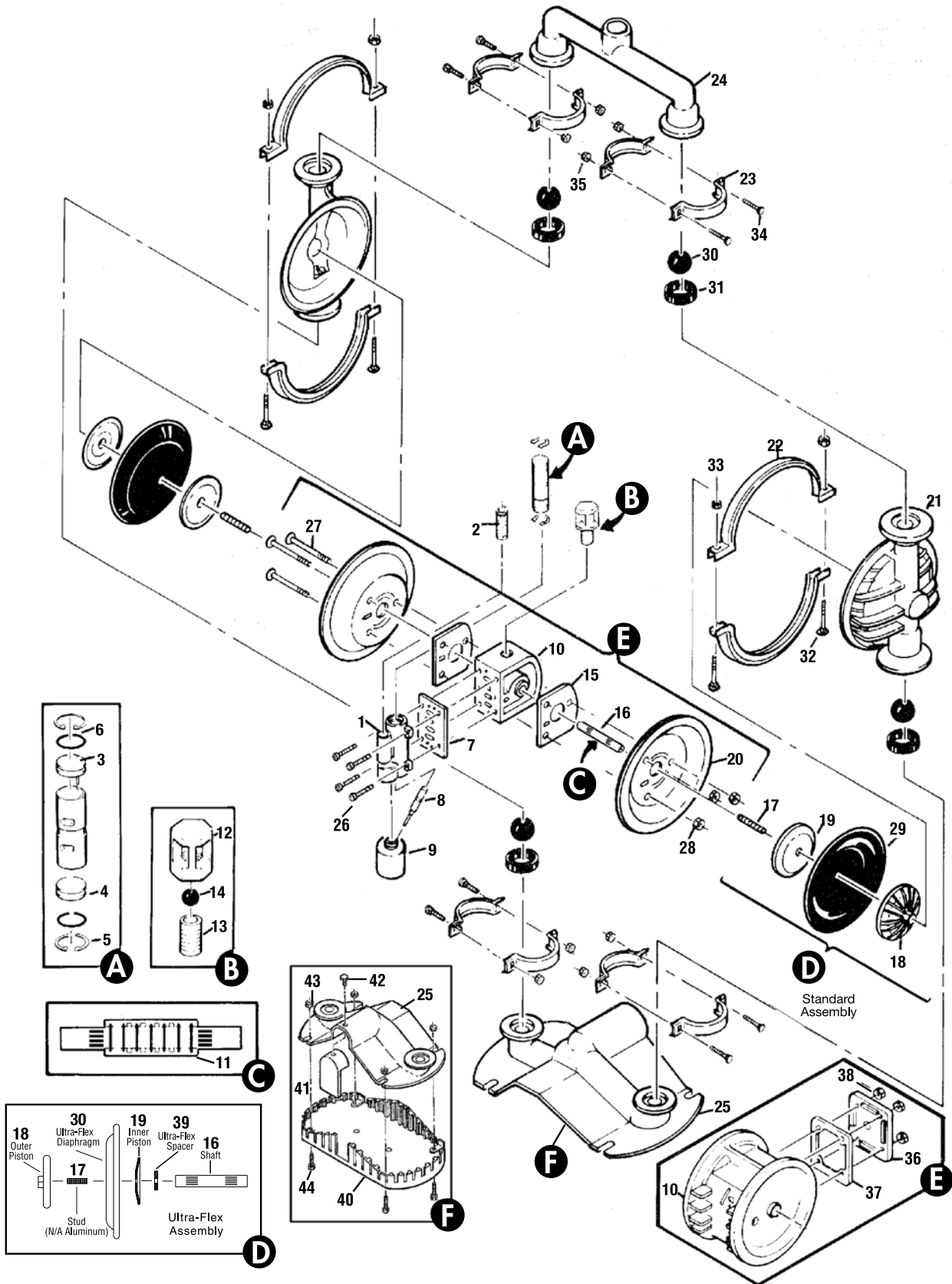

DJT4 Parts List

Item	DJT4/AAMAB Part Number	DJT4/AAMAB Mtl	Description	Qty
1	DJ04-2000-07	Brass	Air Valve	1
2	DJ04-2500-07	Brass	Air Valve Screen	1
3	DJ04-2300-23	Nylon	Air Valve Cap w/Guide (Top)	1
4	DJ04-2330-23	Nylon	Air Valve Cap w/o Guide (Bottom)	1
5	DJ04-2650-03	Stainless steel	Snap Ring	2
6	DJ04-2390-52	Buna-N	Air Valve Cap O-Ring	2
7	DJ04-2600-52	Buna-N	Air Valve Gasket — Buna-N	1
8	DJ04-2900-99	/	Lubricator Capillary Rod Assy. (Optional)	1
9	DJ04-2850-01	Aluminum	Lubricator Oil Bottle (Optional)	1
	N/R	/	Plug (Not shown)	
10	DJ04-3100-01-225	Aluminum	Center Section/Block	1
11	DJ08-3210-55-225	PTFE	Glyd Ring	7
12	N/R	/	1Check Body	1
13	N/R	/	Nipple 3/4" x Close	1
14	N/R	/	Check Ball	1
15	DJ04-3520-30	Cellulose fiber	Block Gasket	2
16	DJ04-3800-09-07	Mild steel, chrome	Shaft	1
	DJ04-3830-09-07	Mild steel, chrome	Shaft, Ultra-Flex	1
17	DJ04-6150-08	Alloy steel	Shaft Stud (M4/WPPB: Bolt)	2
	N/A	/	Stud, Ultra-Flex	2
18	DJ04-4552-01	Aluminum	Piston, Outer	2
	DJ04-4560-01	Aluminum	Piston, Outer, Ultra-Flex	2
19	DJ04-3700-08	Alloy steel	Piston, Inner	2
	DJ04-3760-08	Alloy steel	Piston, Inner, Ultra-Flex	2
20	DJ04-3650-08	Alloy steel	Air Chamber	2
21	DJ04-5000-01	Aluminum	Liquid Chamber	2
22	DJ04-7300-08	Alloy steel	Clamp Band (Large)	2
23	DJ04-7100-08	Alloy steel	Clamp Band (Small)	4
24	DJ04-5020-01	Aluminum	Discharge Manifold	1
25	DJ04-5080-01	Aluminum	Inlet Housing	1
26	DJ04-6000-08	Alloy steel	Air Valve Cap Screw	4
27	DJ04-6130-08	Alloy steel	Hex Head Cap Screw 1/4"-20 x 3"	3
28	DJ04-6400-08	Alloy steel	Hex Head Nut 1/4"-20	3
29	DJ04-1010-50	Polyurethane	Diaphragm	2
	DJ04-1010-51	Neoprene	Diaphragm	2
	DJ04-1010-52	Buna-N	Diaphragm	2
	DJ04-1010-53	Viton	Diaphragm	2
	DJ04-1010-54	EPDM	Diaphragm	2
	DJ04-1010-55	PTFE	Diaphragm	2
	DJ04-1010-56	Hytrel	Diaphragm	2
	DJ04-1010-58	Santoprene	Diaphragm	2
30	DJ04-1080-50	Polyurethane	Valve Ball	4
	DJ04-1080-51	Neoprene	Valve Ball	4
	DJ04-1080-52	Buna-N	Valve Ball	4
	DJ04-1080-53	Viton	Valve Ball	4
	DJ04-1080-54	EPDM	Valve Ball	4
	DJ04-1080-55	PTFE	Valve Ball	4



	DJ04-1080-56	Hytrel	Valve Ball	4
	DJ04-1080-58	Santoprene	Valve Ball	4
31	DJ04-1120-50	Polyurethane	Valve Seat	4
	DJ04-1120-51	Neoprene	Valve Seat	4
	DJ04-1120-52	Buna-N	Valve Seat	4
	DJ04-1120-53	Viton	Valve Seat	4
	DJ04-1120-54	EPDM	Valve Seat	4
	DJ04-1120-56	Hytrel	Valve Seat	4
	DJ04-1120-58	Santoprene	Valve Seat	4
32	DJ04-6070-08	Alloy steel	Large Clamp Band Bolt 5/16"-18 x 21/4"	4
33	DJ04-6420-08	Alloy steel	Large Hex Nut 5/16"-18	4
34	DJ04-6050-08	Alloy steel	Small Clamp Band Bolt 1/4"-20 x 13/4"	8
35	DJ04-6400-08	Alloy steel	Small Hex Nut 1/4"-20	8
36	N/R	/	Muffler Plate	1
37	N/R	/	Muffler Plate Gasket — Buna-N	1
38	N/R	/	Air Valve Hex Nut 1/4"-20	4
39	DJ04-3860-08	Alloy steel	Spacer, Ultra-Flex	2
40	N/R	/	Screen, Stallion	1
41	N/R	/	Suction Cover	1
42	N/R	/	Screw, HHC, 3/8-16 x 7/8"	1
43	N/R	/	Nut, Hex 3/8"-16	4
44	N/R	/	Screw, HHC, 3/8"-16 x 11/2"	4
	N/R	/	Bumper Pad (not shown)	2

